

NOTES:

1. PLEASE CALL 937-428-4782 FOR INSPECTION ONE DAY PRIOR TO PLACEMENT OF ASPHALT.
2. ELEVATION AT RIGHT OF WAY IS EQUAL TO $\frac{1}{2}$ " PER 1' ABOVE TOP OF CURB. A TYPICAL DRIVEWAY AT 10' R/W LINE WILL BE 5" ABOVE THE TOP OF STANDARD HEIGHT CURB.
3. TACK COAT BACK OF CURB PER ODOT 401.14 BEFORE ASPHALT IS PLACED.
4. IF STREET HAS CONCRETE WALK, DRIVE APRON MUST BE CONCRETE.
5. NOTE IF REPLACING CURB: CONTACT INSPECTOR PRIOR TO SAWING CURB. DEPRESSED CURB SHALL BE $1\frac{1}{2}$ " ABOVE THE FLOW LINE OF CURB. 12" HORIZONTAL TRANSITION FOR DEPRESSED CURB.



CITY OF
CENTERVILLE, OH
PUBLIC WORKS DEPARTMENT
7970 SOUTH SUBURBAN ROAD
CENTERVILLE, OHIO 45458
PHONE (937) 428-4782
FAX (937) 433-0286

C441
RESIDENTIAL
ASPHALT DRIVE
APRON

Approval:

James Brinegar
City Engineer

Date: Jan. 2018

Revision: April 2020

Scale:
None

Sheet:

1 of 1

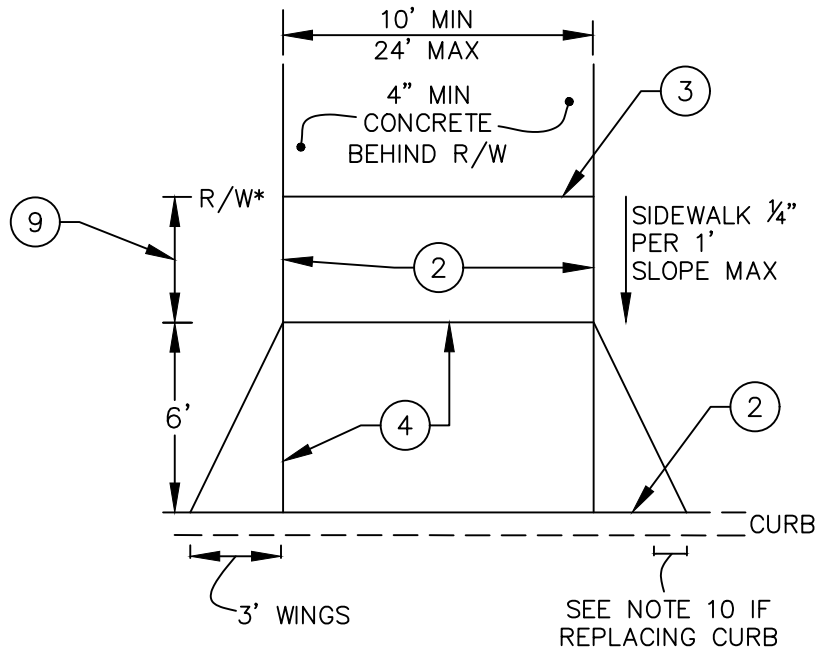
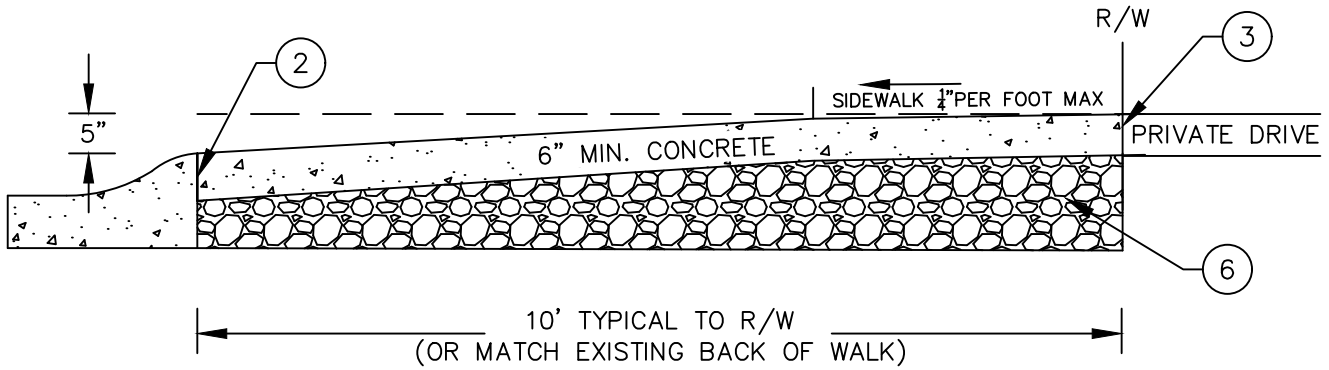

*R/W WIDTHS CAN VARY

NOTES:

1. SET ELEVATION AT BACK OF WALK AT $\frac{1}{2}$ " PER FOOT ABOVE THE TOP OF STANDARD CURB. A TYPICAL DRIVEWAY AT THE BACK OF WALK WILL BE 5" ABOVE THE TOP OF STANDARD CURB HEIGHT.
2. FULL-DEPTH 6" VINYL EXPANSION MATERIAL $\frac{1}{2}$ " THICK REQUIRED. 6" DEEP AT CURB.
3. 4" VINYL EXPANSION MATERIAL
4. TOOLED CONTRACTION JOINT - ALL JOINTS SHALL BE $\frac{1}{2}$ TOOLED JOINTS WITH LIGHT RETRACE (SAW JOINTS PROHIBITED).
5. MINIMUM 6" THICK CONCRETE RESIDENTIAL DRIVE APPROACH ITEM C452 QC MISC MIX IN R/W. 8" MINIMUM FOR COMMERCIAL.
6. ITEM 304 COMPACTED SUBGRADE AND 4" OF AGGREGATE BASE SHALL BE PLACED UNDER DRIVE APPROACH. NO SLAG USE FOR BASE.
7. ALL EXPOSED SURFACES SHALL BE BROOMED AND EDGED. CURING COMPOUND SHALL BE APPLIED ON ALL FINISHED CONCRETE IN R/W PER ITEM 451.11.
8. FOR TREE LAWNS OF LESS THAN 6 FEET IN WIDTH, CALL INSPECTOR PRIOR TO REMOVAL
9. SIDEWALK CAN VARY IN WIDTH DEPENDING ON EXISTING CONDITIONS (4', 5', 8').
10. NOTE IF REPLACING CURB: CONTACT INSPECTOR PRIOR TO SAWING CURB. TOP OF DEPRESSED CURB SHALL BE $1\frac{1}{2}$ " ABOVE THE FLOW LINE OF CURB. 12" HORIZONTAL TRANSITION FOR DEPRESSED CURB. CURB AND DRIVEWAY SHALL BE POURED SEPARATELY.



CITY OF
CENTERVILLE, OH
PUBLIC WORKS DEPARTMENT
7970 SOUTH SUBURBAN ROAD
CENTERVILLE, OHIO 45458
PHONE (937) 428-4782
FAX (937) 433-0286

C452
RESIDENTIAL
CONCRETE DRIVE
APRON

Approval:

James Brinegar
City Engineer

Date: Jan. 2018
Revision: April 2020
Scale: None
Sheet: 1 of 1